

OWNER'S MANUAL

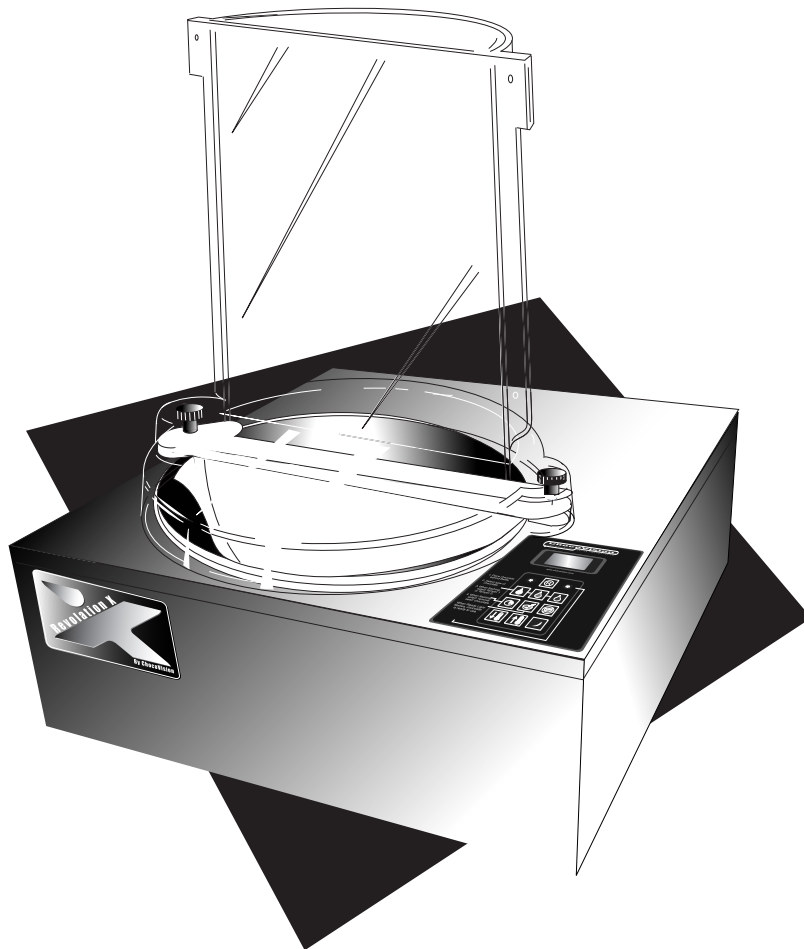

Revolution X3210 **CHOCOLATE TEMPERING SYSTEM**

ChocoVision™
Technology MEANS PRODUCTIVITY

P.O. BOX 5201 POUGHKEEPSIE, NY 12602
TEL (845) 473-4970 (845) 473-5453 FAX (845) 473-8004



www.chocovision.com

INTRODUCTION

Congratulations on your purchase of the new Revolution X3210 Chocolate Tempering Machine by ChocoVision

The ChocoVision line of "Revolution Chocolate Makers" has been widely accepted among the homemakers, hobbyists, restaurants, hotels, coffee shops, bakeries, and even highly accomplished pastry chefs. For the first time ever, the complicated process of properly tempering chocolate can be easily performed by anyone.

By combining the subtle nuance of precise temperature control with sophisticated microprocessor electronics, the "Revolution" line of Chocolate Tempering Machines has proven itself a serious performer in this demanding environment.

We hope you will enjoy the use of your Revolution X3210 Chocolate Tempering Machine for many years to come. It has been designed to provide the user with precision, accuracy, efficiency, and unmatched reliability. We take great pride in providing you with the highest quality product and superior service.

TABLE OF CONTENTS

INTRODUCTION / CONTENTS.....	1
SAFETY TIPS.....	2
YOUR MACHINE.....	3
ASSEMBLY.....	4
THE CONTROLS.....	5
USING YOUR MACHINE.....	5
TIPS.....	6
BEFORE YOU CALL SERVICE.....	6
CLEANING.....	7
QUICK START.....	7

IMPORTANT SAFETY TIPS

PLEASE READ AND UNDERSTAND THE FOLLOWING SAFETY MEASURES BEFORE USING YOUR MACHINE

-FOR PERSONAL SAFETY, THIS APPLIANCE MUST ALWAYS BE PLUGGED INTO A PROPERLY GROUNDED ELECTRICAL CIRCUIT.

-DO NOT CUT OR REMOVE THE THIRD (GROUND) PRONG FROM THE POWER PLUG, OR ATTEMPT TO USE A GROUNDING ADAPTOR.

-NEVER IMMERSE THE MACHINE IN WATER. (SEE CLEANING INSTRUCTIONS ON PAGE 7.)

-ALWAYS LOCATE THE MACHINE AWAY FROM ANY WATER SOURCE. AVOID WATER SPLASHING ON TOP OR INTO THE MACHINE, OR NEAR THE FAN AREAS.

-NEVER USE EXTENSION CORDS TO POWER THE MACHINE.

-TO AVOID SUFFOCATION, KEEP ALL PACKING MATERIAL, (PLASTIC BAGS AND SMALL PARTS) AWAY FROM CHILDREN.

-POSITION MACHINE SUCH THAT THE INTAKE AND EXHAUST FANS ARE NOT OBSTRUCTED, OR THAT ANY LOOSE OBJECTS CAN NOT BLOCK AIR FLOW.

-UNPLUG MACHINE FROM POWER SOURCE WHEN NOT IN USE.

-ALWAYS UNPLUG YOUR MACHINE BEFORE CLEANING. NEVER USE SPRAY SOLVENTS OR CLEANING FLUIDS NEAR THE MACHINE.

-TO AVOID ELECTRICAL SHOCK, NEVER OPEN CASE.

-NEVER ALLOW MELTED CHOCOLATE TO HARDEN IN THE BOWL WITH THE BAFFLE IN PLACE. ACCIDENTAL STARTING OF THE MACHINE IN THIS CONDITION COULD CAUSE INTERNAL COMPONENT DAMAGE, OR PRESENT ELECTRICAL HAZARDS.

YOUR MACHINE

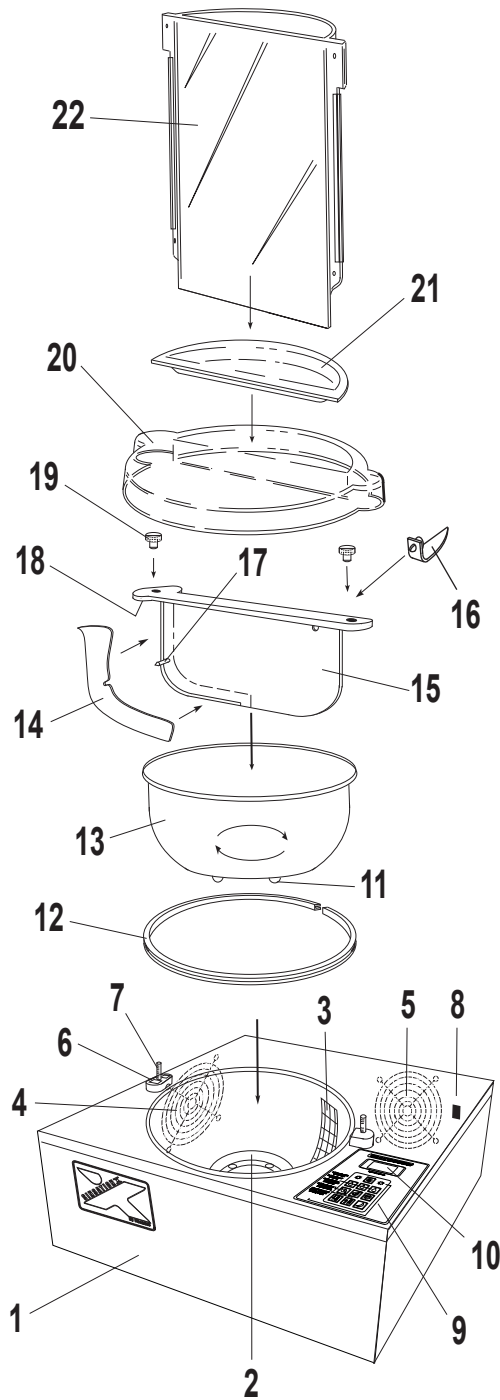

- 1. MAIN CASE
- 2. BOWL COUPLER
- 3. HEAT OUTLET
- 4. EXHAUST FAN
- 5. INTAKE FAN
- 6. PROBE CONTACTS (CASE)
- 7. BAFFLE MOUNTS (2)
- 8. POWER SWITCH
- 9. KEYPAD
- 10. DISPLAY WINDOW
- 11. BOWL LOCATORS
- 12. BOWL RING
- 13. BOWL
- 14. SCRAPER
- 15. BAFFLE
- 16. BAFFLE CLIP
- 17. PROBE
- 18. PROBE CONTACTS (BAFFLE)
- 19. BAFFLE KNOBS (2)
- 20. DUST COVER
- 21. DUST COVER LID
- 22. HOPPER

NOTE : When using HOPPER, DUST COVER LID cannot be used.

ASSEMBLY

NOTE: BEFORE USING YOUR MACHINE, WASH ALL COMPONENTS THAT MAY COME IN CONTACT WITH CHOCOLATE. USE A SOFT SPONGE OR CLOTH AND MILD SOAP.

* Install the removable **BOWL RING** onto the lip of the bowl opening in your machine.

* Place the **BOWL** in your machine and rotate it until it drops into place.

* Attach the **SCRAPER** to the **BAFFLE** (Fig. 1). When properly installed, the **SCRAPER** should curve towards the front of the machine.

* Fit the **BAFFLE** into the **BOWL**, insuring that the probe contacts (**CASE** and **BAFFLE**) are aligned. Thread the **BAFFLE KNOBS** onto both **BAFFLE MOUNTS**. If the **BAFFLE** is not installed properly, the machine will sound an audible warning, and will not start.

* Snap in the **BAFFLE CLIP**. This helps the solid chocolate from climbing out of the bowl as it rotates.

OPTIONAL HOPPER ACCESSORY

* Slide the **HOPPER** assembly into the **DUST COVER** opening (Fig. 2) and load with up to 10 lbs of chocolate. Any type of chocolate can be used, but solid block chocolate works best.

* Note that chocolate is always loaded behind the **BAFFLE**.

* All **HOPPER** components can be disassembled for easy cleaning.

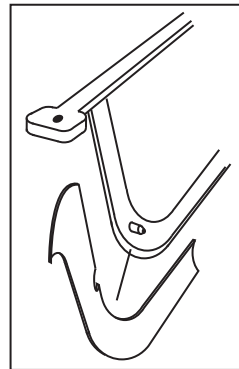

Fig. 1

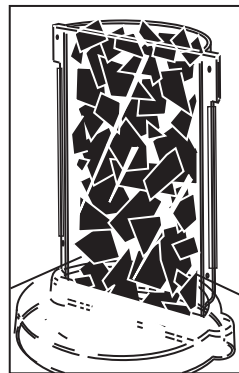
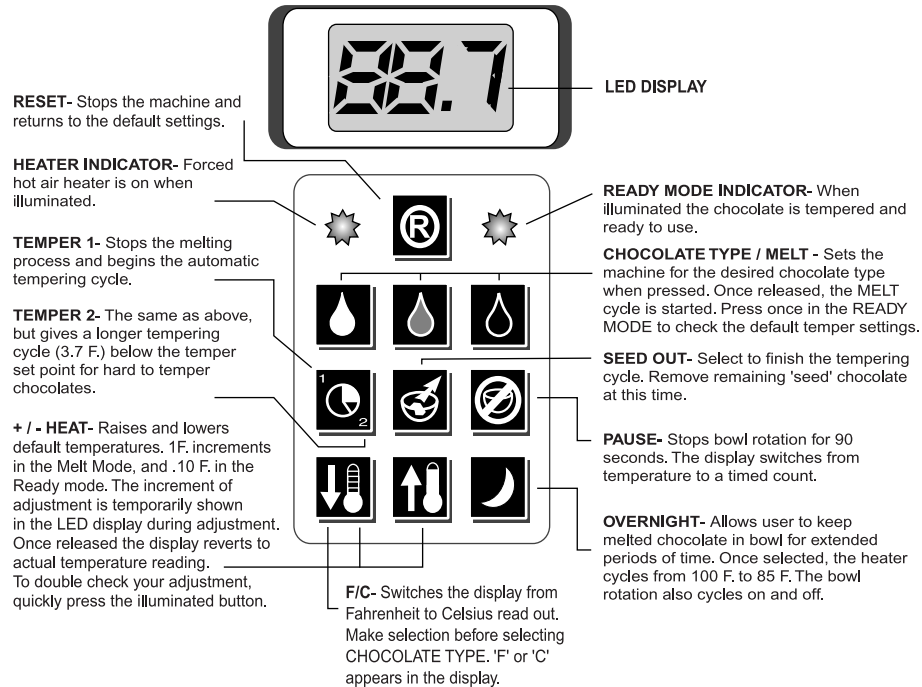

Fig. 2

THE CONTROLS



USING YOUR MACHINE

1) Assemble and turn POWER SWITCH to ON position. Load chocolate behind the baffle. (Solid block pieces work best). You can load up to 10 lbs. of chocolate at a time if you are using the optional HOPPER assembly.

2) Select the type of chocolate you wish to temper by pressing for WHITE, for MILK, or for DARK. Once released the Melting process begins. As the chocolate begins to melt it will collect in a pool in front of the SCRAPER, near the PROBE. Depending on the average room conditions, it will take approximately 45 minutes to melt 10 lbs of chocolate.

NOTE: If the chocolate your using requires a higher than 108F. melt temperature, press and hold the +HEAT. To check the default Melt temperature, press CHOCOLATE TYPE/MELT during the melting process.

3) Once flashing, and you have the desired amount of chocolate melted, press the TEMPER 1 button. If 'Seed' chocolate is not in good condition, press and hold the button for TEMPER 2.

4) Place at least 224 gms (8 oz) of solid, tempered chocolate ('Seed') behind the baffle, per 10 lb. batch. The tempering process will take around 10-15 minutes.

5) Press the SEED OUT button when flashing, and remove any remaining 'Seed' chocolate at this time. This will happen at a nominal 90F.

When the machine finishes the final phase of tempering, you will hear three beeps, the READY INDICATOR light illuminates. The chocolate is now tempered and is ready to use.

TIPS & HELPFUL HINTS

TEMPERING LARGE QUANTITIES. You can replenish the pool of chocolate by adding pre-melted batches behind the baffle while in the TEMPER mode. We recommend that the pre-melted chocolate temperature does not exceed 34 C. (94 F). Set the machine to the MELT mode if you do not plan on using your tempered chocolate for extended periods of time (over two hours). Re-temper when chocolate is needed again.

WORK AREA. The ideal average room temperature should be between 20-22 C. (68-72 F), with the average humidity not above 50 %. Air conditioned environments work best. Never allow water to mix with melted chocolate. Never store chocolate in a refrigerated environment, as condensation (water) may form on the chocolate surface when brought out at room temperature. Always make sure that all items being dipped into the tempered chocolate (like fruit), are at room temperature, and COMPLETELY dry, including all utensils being used.

PRODUCT SIZE. If you are producing solid thick products, like molds, thoroughly mix the tempered chocolate batch before you pour. With a fan, moving large volumes of air across the product helps in the cooling process.

TEMPERATURE / THICKNESS. You can manually adjust the viscosity of your tempered chocolate by adjusting the temperature setting in the READY mode. Increasing the heat will make the chocolate thinner, and decreasing the heat will make the chocolate thicker. To do so, press and hold the buttons marked **+** HEAT or **-** HEAT. Each stroke of these buttons raises and lowers the temperature in .01 F. steps. Button illumination is accompanied with heat adjustment for quick view convenience. To check the custom temperature adjustment, press the illuminated HEAT button once and your adjustment will appear in the LED display. Once released the display reverts to the actual temperature reading.

BEFORE YOU CALL FOR SERVICE.....

? **MY MACHINE WON'T START.** Make sure that your contacts on your BAFFLE and CASE are making good connection. These contacts should be clean and free of chocolate.

? **THE MELTED CHOCOLATE DOES NOT POOL IN FRONT OF THE BAFFLE.** Check the installation of the SCRAPER. The SCRAPER should be curved forward (against the BOWL, and towards the front of the machine) when properly installed into the BAFFLE.

? **THE CHOCOLATE THICKENS.** The chocolate may have picked up moisture from dipping fresh fruits, or from high room humidity (see above under TIPS & HELPFUL HINTS). The pool of chocolate was left in the TEMPER mode too long. (see above under TIPS & HELPFUL HINTS). The 'seed' chocolate was not removed on time, causing the tempered pool to thicken. You can simply press the MELT button and start over.

? **THE CHOCOLATE CLIMBS OUT OF THE BOWL.** Make sure that the BAFFLE CLIP is properly installed onto the BAFFLE. Solid block chocolate works best.

CLEANING

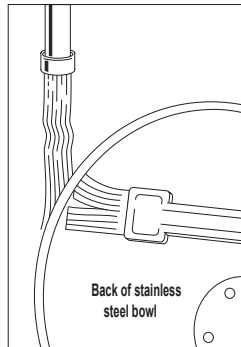

FIG. 1

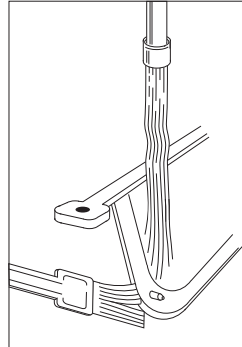
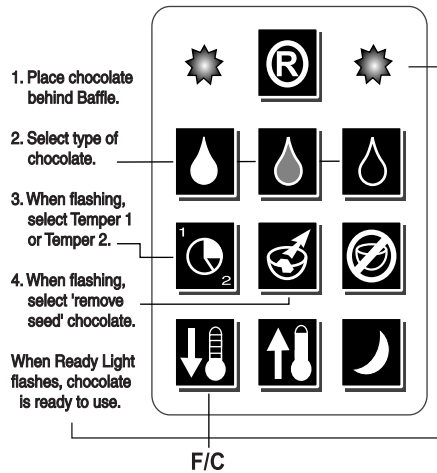

FIG. 2

Your machine includes a special **CLEANING BRUSH** for areas where chocolate collects and may be difficult to clean, such as the inside of the **BOWL RING**, behind the lip of the stainless steel **BOWL** (Fig. 1), and crevices on the **BAFFLE** (Fig.2).

Never use steel wool or any other type of abrasive to clean your machine, or any components included with your machine. Only use a sponge or a soft cloth with mild soap to wipe down the outside **CASE**.

QUICK START



MANUFACTURED IN THE U.S.A. WITH PRIDE AND CRAFTSMANSHIP

ChocoVision Corporation